

LW-SCM SERIES

LIGHTWEIGHT SPRING CUP MOUNTS



DESTACO's new light weight spring cup mounts are designed to be lighter than our current heavy duty spring cup mounts. The LW-SCM series is typically used in sheet metal stamping applications to accommodate multiple thickness panel stacks and cushion the panel during drop off.

The construction is modular design with a common base unit and multiple mounting options. While the LW-SCM is intended for vertical use, it features a pair of widely spaced maintenance-free bushings to better accommodate minor off-axis loading for long life. Mounting options include an apple core, bulkhead, or clamp style for tube mounts.

Air connections are built-in to allow connection of DESTACO venturi vacuum generators or air fitting for remote vacuum, and vacuum cups are installed on the bottom mounting threads for secure pick up and part handling.



PRODUCT HIGHLIGHTS/OPTIONS

- Bulkhead, apple core mounting
- Metric or Imperial tube mounting
- Metric or Imperial air connection ports
- 3 travel lengths available



PICK AND PLACE

FEATURES & BENEFITS



PERFORMANCE

- Non-rotating shaft for accurate part/sheet placement
- Proven design for smooth and consistent, long-lasting operation
- Tested to 3M cycles



LOW-NO MAINTENANCE

- Maintenance-free bushings for long life and no lubrication required
- Shaft is hard-coat anodized with teflon for consistent smooth operation



INTERCHANGEABLE

- Metric or Imperial air connection port
- Metric or Imperial vacuum cup mounting
- Bulkhead, Apple Core or tube mounting



PRESS ROOM/
STAMPING

APPLICATIONS



AUTOMOTIVE



INDUSTRIAL

MARKETS

LW-SCM SERIES LIGHTWEIGHT SPRING CUP MOUNTS

The LW-SCM Series is smaller and lighter than our current heavy-duty spring cup mounts offering. This allows our customers the opportunity to run their automation faster, increasing their productivity. Using the LW-SCM Series also help lower maintenance costs by reducing wear and tear on their robots and automation.

Three mounting options:

- Bulkhead style for threaded or through hole mounting (M27x2)
- Apple Core style for mounting at the end of a swivel arm (Ø0.75")
- Clamp style for tube mounting (Ø40mm/1.50")

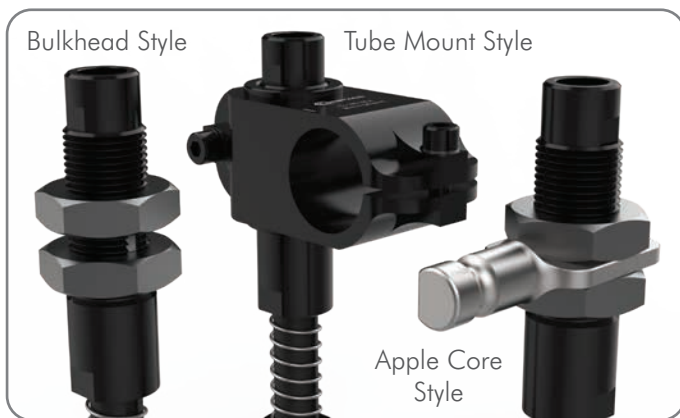

Metric or Imperial air connection port options available.

- 3/8 NPT (Black)
- ISO G3/8 (Blue)

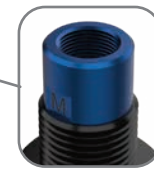

(Metric option shown on clamp style)

Three travel lengths available

- 50mm/2.00"
- 100mm/4.00"
- 150mm/6.00"

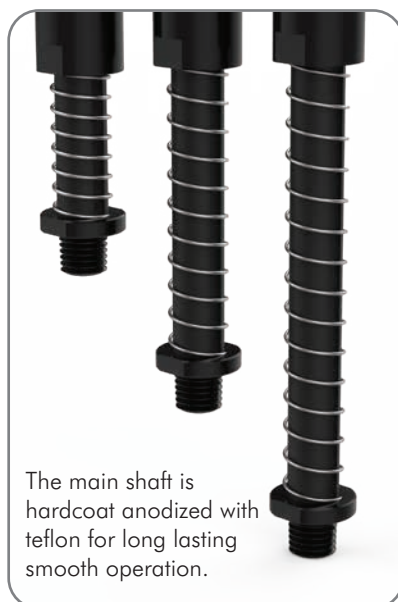

Metric or Imperial vacuum cup mounting

- 3/8 NPT (Black)
- ISO G3/8 (Blue)



DIMENSIONS AND TECHNICAL INFORMATION ARE SUBJECT TO CHANGE WITHOUT NOTICE.